

# AQUADYN<sup>®</sup> UA 1060

Basic Information and Requirements for Plant Design,  
Process Engineering and Control Systems



USER GUIDELINE

Version M\_UA1060\_Guideline\_V1\_01e



MICRODYN  
NADIR

ADVANCED SEPARATION TECHNOLOGIES

## Table of Contents

1. Introduction.....	2
2. Specification of feed water The following specifications regarding the feed water quality/composition have to be observed: .....	2
3. Requirements for the System Design and Process Engineering: .....	2
4. Operating Cycles and Cleaning of AQUADYN® UA1060 Modules .....	4
5. Recommended Data Measurements and logging for AQUADYN® UA1060 systems.....	5

## Table of Figures

Figure 1: Example of Rack Design with AQUADYN® UA1060 Modules .....	4
---	---

## Table of Attachments

Attachment 1: Data Sheet of AQUADYN® UA1060 Module.....	6
Attachment 2: Basic P&ID for an AQUADYN® Plant with UA1060 Modules.....	7

MICRODYN-NADIR behält sich das Recht vor, Angaben ohne vorherige Ankündigung anzupassen.

We reserve the right to change specifications without prior notification.

MICRODYN-NADIR GmbH  
Industriepark Kalle-Albert  
Kasteler Straße 45  
D-65203 Wiesbaden

Telefon: +49 (0) 611/962-6001  
Telefax: +49 (0) 611/962-9237  
E-Mail: [info@microdyn-nadir.de](mailto:info@microdyn-nadir.de)  
Internet: [www.microdyn-nadir.de](http://www.microdyn-nadir.de)



## 1. Introduction

The AQUADYN® UA1060 modules are hollow fiber modules for water applications based on a hydrophilic PAN ultrafiltration membrane. Due to the outside – to - inside operation and the optimized module design, the modules can be applied in feed water with high turbidity and high suspended solids loads.

The following requirements for the design of plants with AQUADYN® UA1060 modules are based on the most current knowledge of MICRODYN-NADIR GmbH and might be subject to change over time. When designing a plant, please check with your local sales representative if you have the most current version of these guidelines.

## 2. Specification of feed water

**The following specifications regarding the feed water quality/composition have to be observed:**

1. The water temperature has to be between 4°C and 45°C (41°F and 113°F).
2. The pH has to be between 2 and 10.
3. The turbidity has to be less than 300 NTU\*.
4. The concentration of suspended solids has to be below 350 mg/l\*.
5. The feed water does not contain any organic solvents.
6. The concentration of hydrocarbons is less than 1 mg/l\*.
7. No oxidizing substances exist in the feed water. The only exception is the back flush with free chlorine for the enhanced back flush (EBF)

\*If values are outside the given range a pilot test is required

## 3. Requirements for the System Design and Process Engineering:

1. The pre-filtration to the AQUADYN® modules should be  $\leq 100 \mu\text{m}$ . We recommend self-cleaning filter devices.
2. The maximum operating pressure for the AQUADYN® UA1060 module is 1.2 bar (17.4 psi).
3. The maximum applicable trans-membrane pressure (TMP) is 1 bar (14.5 psi). We recommend a TMP of 0.2 to 0.6 bar (2.9 to 8.7 psi).
4. The system has to be operated with a yield  $\leq 97\%$ .
5. The system has to be operated with a periodic concentrate discharge.
6. The system is usually based on racks with 1 or 2 rows of AQUADYN® UA1060 modules on each side of the headers. The maximum number of modules per row is 12, which results in a maximum of 48 modules per rack. Irrespective of the system configuration, the flow velocity in the interconnections/manifolds between the modules has to be less than 2 m/s (6.6 ft/s).
7. Based on the required permeate flux per AQUADYN® UA1060 module, the feed pump must have a capacity of twice the permeate flux per module but less than 14.4 m<sup>3</sup>/h (63.4 gpm) at max. 1.2 bar (17.4 psi). For example, for a rack with 24 modules the maximum capacity of the feed pump is 345 m<sup>3</sup>/h (1519 gpm) at 1.2 bar (17.4 psi).
8. Based on the required permeate flux per AQUADYN® UA1060 module, the back flush pump must have a capacity of twice the permeate flux per module but less than 14.4 m<sup>3</sup>/h (63.4

MICRODYN-NADIR behält sich das Recht vor, Angaben ohne vorherige Ankündigung anzupassen.

We reserve the right to change specifications without prior notification.

MICRODYN-NADIR GmbH  
Industriepark Kalle-Albert  
Kasteler Straße 45  
D-65203 Wiesbaden

Telefon: +49 (0) 611/962-6001  
Telefax: +49 (0) 611/962-9237  
E-Mail: [info@microdyn-nadir.de](mailto:info@microdyn-nadir.de)  
Internet: [www.microdyn-nadir.de](http://www.microdyn-nadir.de)



gpm) at max. 1.2 bar (17.4 psi). For example, for a rack with 24 modules the maximum size of the back flush pump is 345 m<sup>3</sup>/h (1519 gpm) at 1.2bar (17.4 psi).

9. The installed blower for the air scouring has to provide 3 to 10 Nm<sup>3</sup>/h (1.8 to 5.9 scfm) at maximal 1.2 bar (17.4 psi) per AQUADYN<sup>®</sup> UA 1060 modules (For a rack with 24 modules a blower of 72 to 240 Nm<sup>3</sup>/h (42 to 141 scfm) at 1.2 bar (17.4 psi) is needed)
10. The piping of the plant has to be dimensioned so that the modules can be operated without problems in a range of 0.2 to 1.2 bar (2.9 to 17.4 psi).
11. The velocity in the headers of permeate, feed and concentrate has to be less than 2 m/s (6.6 ft/s) at the maximum flow during forward flush and back flush.
12. On both sides of the module water hammers are strictly forbidden (the use of frequency converter for feed and back flush pump is recommend.)
13. It has to be ensured that the system can be completely de-aerated.
14. The design of the system should not allow for any dead zones on the permeate side because areas without flow will inhibit the effectiveness of the chemical enhanced back flush (EBF) and therefore impact module performance negatively.
15. It has to be ensured that during forward flush and back flush operation the concentrate can be completely flushed out of the AQUADYN<sup>®</sup> UA1060 modules.
16. After EBF and CIP, residuals of chlorine might be present in the modules. A forward flush has to be performed to remove chlorine residuals from outside the membranes. A back flush or filtration to drain has to be performed if necessary to remove chlorine residuals from inside the membrane.
17. The design of the system has to ensure that sufficient water volumes will be available for forward flush and back flush considering flow rate and duration.
18. There is no permeate supply during the regeneration of the system. This has to be taken into consideration when sizing the system.
19. It is recommended to operate the plant with constant flow rate or constant TMP.

MICRODYN-NADIR behält sich das Recht vor, Angaben ohne vorherige Ankündigung anzupassen.

We reserve the right to change specifications without prior notification.

MICRODYN-NADIR GmbH  
Industriepark Kalle-Albert  
Kasteler Straße 45  
D-65203 Wiesbaden

Telefon: +49 (0) 611/962-6001  
Telefax: +49 (0) 611/962-9237  
E-Mail: [info@microdyn-nadir.de](mailto:info@microdyn-nadir.de)  
Internet: [www.microdyn-nadir.de](http://www.microdyn-nadir.de)



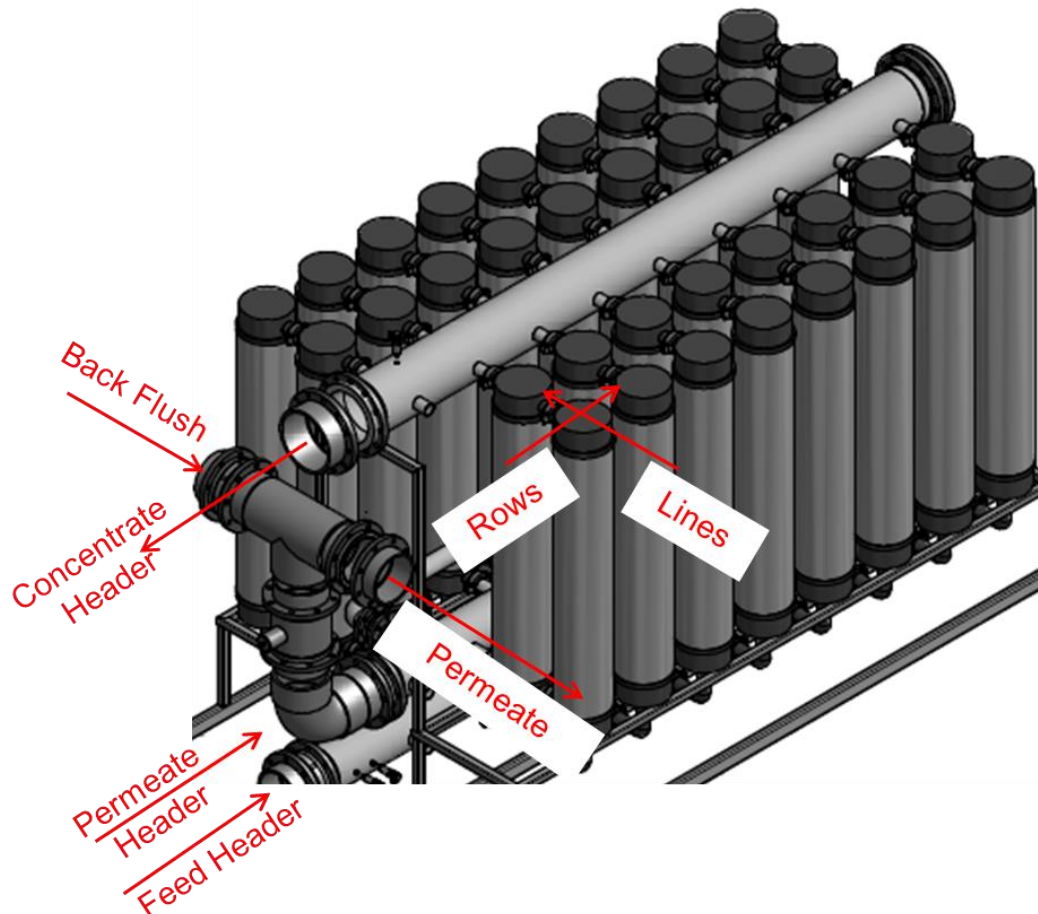

**Figure 1: Example of Rack Design with AQUADYN® UA1060 Modules**

#### 4. Operating Cycles and Cleaning of AQUADYN® UA1060 Modules

1. Filtration cycles have to last 30 to 60 minutes in dead-end mode.
2. Air scouring has to be applied every 30 to 60 minutes for 30 to 60 seconds.
3. Forward flush has to be applied every 30 to 60 minutes for 30 to 60 seconds.
4. Back flush has to be applied every 30 to 60 minutes for 30 to 60 seconds at 1 to 1.2 bar (14.5 to 17.4 psi).
5. Enhanced back flush (EBF) has to be applied every 3 to 10 days with less than 50 ppm free chlorine for 30 to 90 seconds with a soaking time of 5 to 20 minutes.
6. Complete drainage of all modules via feed manifold after each EBF is required.
7. CIP has to be applied every 20 to 90 days with  $\leq 100$  ppm free Chlorine, alkaline solutions with  $\text{pH} \leq 10$  or acid solutions at  $\text{pH} 2$  to  $3$  for 2 to 4 hours depending on raw water quality.
8. The  $\text{pH}$  value of the water used for CIP with chlorine has to be adjusted to  $6.8 - 7$ .
9. The maximum applicable free chlorine concentration for enhanced back flush (EBF) and CIP cleaning is 100 ppm.
10. The maximum chlorine exposure time is 100,000 ppmh
11. Tap water or permeate has to be used for CIP solution.

MICRODYN-NADIR behält sich das Recht vor, Angaben ohne vorherige Ankündigung anzupassen.

We reserve the right to change specifications without prior notification.

MICRODYN-NADIR GmbH  
 Industriepark Kalle-Albert  
 Kasteler Straße 45  
 D-65203 Wiesbaden

Telefon: +49 (0) 611/962-6001  
 Telefax: +49 (0) 611/962-9237  
 E-Mail: [info@microdyn-nadir.de](mailto:info@microdyn-nadir.de)  
 Internet: [www.microdyn-nadir.de](http://www.microdyn-nadir.de)



## 5. Recommended data measurements and logging for AQUADYN® UA1060 Systems

1. Permeate flow: This data should be measured and recorded continuously.
2. Feed water temperature: This data should be measured and recorded continuously.
3. Turbidity of feed water: This data should be measured and recorded continuously.
4. pH of feed water: This data should be measured and recorded continuously.
5. Turbidity of permeate: This data should be measured and recorded continuously.
6. The forward flush and back flush flows have to be recorded daily and logged into an operations diary.
7. The inlet pressure and the transmembrane pressure of the modules during filtration and back flushing have to be measured continuously and the data has to be recorded.
8. The cleaning of the modules has to be documented in the operation diary specifying cleaning times, temperature, chemicals used, concentration and amount of chemicals, the amount of rinsing solutions, as well as the duration of the cleaning cycle.

In case of further question about the use AQUADYN® UA1060 modules please contact your local sales engineer or get in contact with our office in Germany.

MICRODYN-NADIR behält sich das Recht vor, Angaben ohne vorherige Ankündigung anzupassen.

We reserve the right to change specifications without prior notification.

MICRODYN-NADIR GmbH  
Industriepark Kalle-Albert  
Kasteler Straße 45  
D-65203 Wiesbaden

Telefon: +49 (0) 611/962-6001  
Telefax: +49 (0) 611/962-9237  
E-Mail: [info@microdyn-nadir.de](mailto:info@microdyn-nadir.de)  
Internet: [www.microdyn-nadir.de](http://www.microdyn-nadir.de)



# AQUADYN® UA1060

## - Hollow Fiber Module -

### Data Sheet

#### Module Specification

Filtration type	Ultrafiltration
Membrane type	Hollow fiber
Membrane structure	Double asymmetric
Membrane potting	Epoxy
Membrane material	PAN
Housing material	uPVC
Fiber arrangement	U-Shape
Flow type	Out/In
Type of filtration	Dead End
Regeneration	Back Flush, Forward Flush, Air Scouring
Membrane area	60 m <sup>2</sup> /646 ft <sup>2</sup>
Hollow fiber diameter OD/ID	1.7 mm/0.9 mm
Pore size	0.025 µm
Module diameter	267 mm/10.5 in
Module length	1737 mm/68.4 in
Connectors	Feed port: 2" Victaulic Permeate port: 2" Victaulic Reject port: 2" Victaulic Air inlet port: G1/2"
Weight of module at shipping	Approx. 41 kg/90.4 lbs
Standard preservative	Sodium meta-bisulphite

#### Operation Specification\*

	SI Units	US Units
Applicable water flux	≤ 7.2 m <sup>3</sup> /h	≤ 31.7 gpm
Capacity feed pump	≤ 14.4 m <sup>3</sup> /h	≤ 63.4 gpm
Capacity back flush pump	≤ 14.4 m <sup>3</sup> /h	≤ 63.4 gpm
Max. transmembrane pressure	1 bar	14.5 psi
Max. module pressure	1.2 bar	17.4 psi
Applicable air scour rate	3 - 10 Nm <sup>3</sup> /h	1.8 - 5.9 scfm
Air pressure	< 1.2 bar	< 17.4psi
Temperature range	5 - 45°C	41 - 113°F
pH range, operation	2 - 10	
pH range, cleaning	1 - 10	
Max. TSS feed	≤ 350 mg/L	
Max. NTU feed	≤ 300 NTU	

\* Depending on feed water quality and operating conditions

Note: The information in this data sheet believed to be accurate and reliable, but is not to be construed as implying any warranty or guarantee of performance.

MANN+HUMMEL ULTRA-FLO Pte Ltd. Is the manufacturer of the UE & UA modules: the modules are marketed and distributed under the name AQUADYN® which is a registered trademark of MICRODYN-NADIR GmbH in Europe.

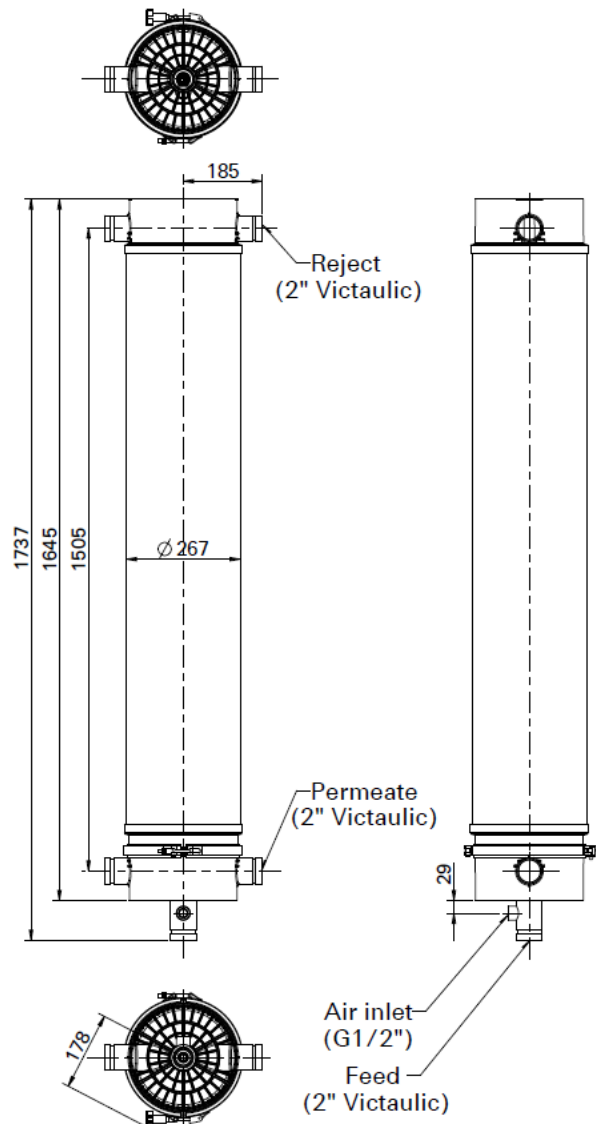

MICRODYN-NADIR behält sich das Recht vor, Angaben ohne vorherige Ankündigung anzupassen.

We reserve the right to change specifications without prior notification.

MICRODYN-NADIR GmbH  
Industriepark Kalle-Albert  
Kasteler Straße 45  
D-65203 Wiesbaden

Telefon: +49 (0) 611/962-6001  
Telefax: +49 (0) 611/962-9237  
E-Mail: info@microdyn-nadir.de  
Internet: www.microdyn-nadir.de



**Attachment 2: Basic P&ID for an AQUADYN® Plant with UA1060 Modules**

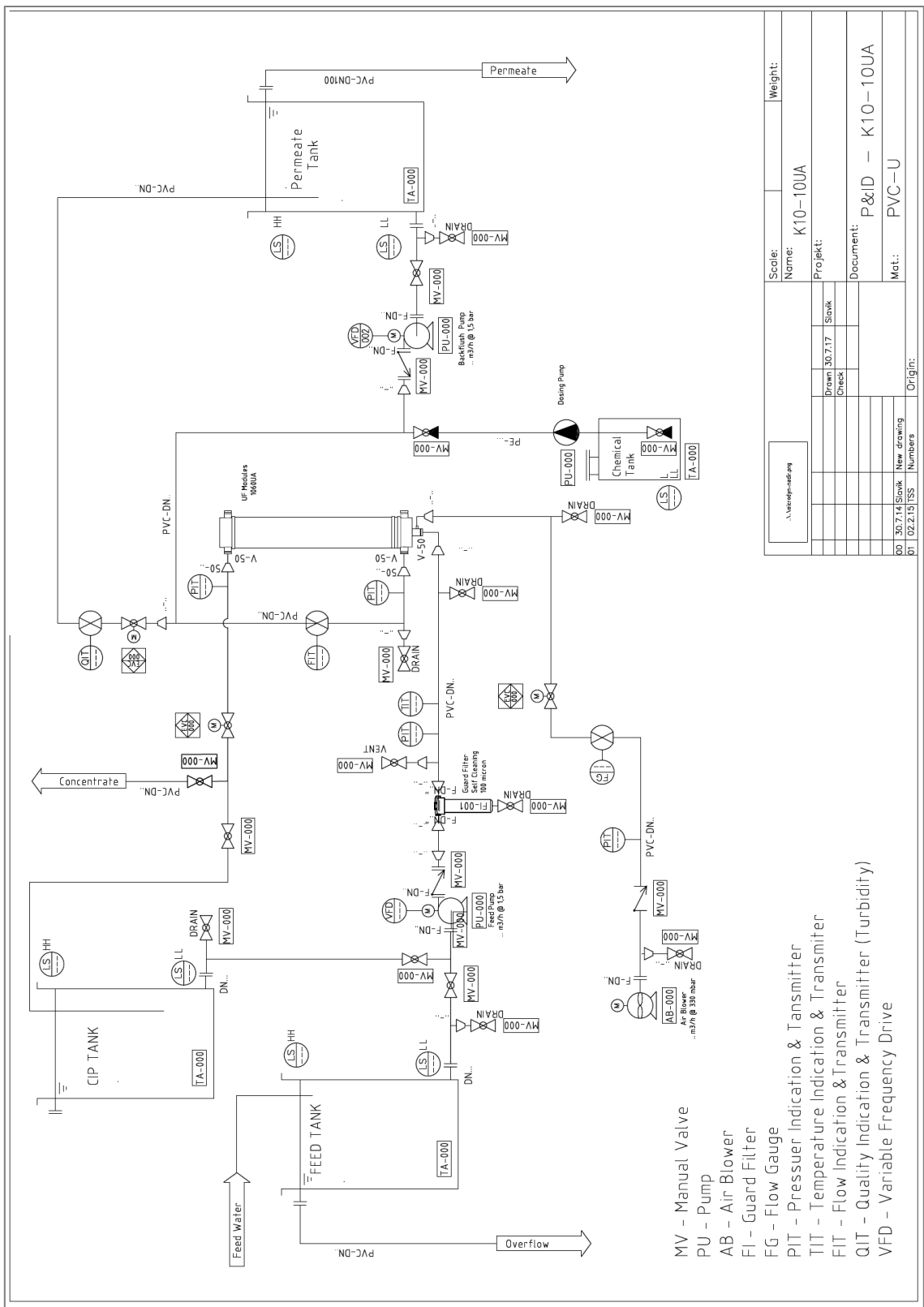

Scale:		Name:		Weight:	
		K10-10UA			
Project:		Document:		Mat.:	
30.7.17		P&ID – K10-10UA		PVC-U	
Drawn:		Origin:			
Check:		New drawing		Numbers	
		01		02.2.15	
		00		30.7.14	
		01		02.2.15	

MICRODYN-NADIR behält sich das Recht vor, Angaben ohne vorherige Ankündigung anzupassen.  
 We reserve the right to change specifications without prior notification.

MICRODYN-NADIR GmbH  
 Industriepark Kalle-Albert  
 Kasteler Straße 45  
 D-65203 Wiesbaden

Telefon: +49 (0) 611/962-6001  
 Telefax: +49 (0) 611/962-9237  
 E-Mail: info@microdyn-nadir.de  
 Internet: www.microdyn-nadir.de

