



MICRODYN
NADIR

ADVANCED SEPARATION TECHNOLOGIES

MOLSEP[®]

Manual for

MOLSEP[®] Hollow Fibre

Cartridge FS10... and FE10...



MOLSEP[®] Hollow Fibre Cartridge

MICRODYN-NADIR GmbH
Rheingastr. 190-196 D-65203 Wiesbaden
Tel. + 49 (0) 611 962-6001 Fax: + 49 (0) 611 962-9237
info@microdyn-nadir.de
www.microdyn-nadir.de



Table of Content

1. Introduction	4
2. Description of MOLSEP[®] Hollow Fibre Module	5
3. Module Selection	5
4. Product Code	6
5. Condition as Supplied	7
6. Handling the Module	8
7. Mounting the Module	8
8. Start-Up Procedure	9
9. Operating Conditions	10
10. Cleaning and Regeneration	10
11. Pasteurisation	12
12. Long-term Storage	12
13. Module Lifetime	12

Attachments:

Table 1: Specification and operating conditions	13
Table 2: Chemical resistance of polyethersulfone membrane (FUS-Module)	14
Table 3: Chemical resistance of polyacrylonitrile membrane (FUY-Module)	14
Fig. 1: Technical drawing, Type: FS10-FS	15
Fig. 2: Technical drawing, Type: FS10-FC	16
Fig. 3: Technical drawing, Type: FE10-FC	17
Fig. 4: Technical drawing, Type: FE10-FC (with connections)	18



Fig. 5:	Membrane system with backwashing	19
Fig. 6:	Forward, backward switching membrane system with backwashing	19
Fig. 7:	Membrane system without backwashing	20
Fig. 8:	Circulating Membrane system without backwashing	20



MICRODYN
NADIR

ADVANCED SEPARATION TECHNOLOGIES

1. Introduction

This instruction brochure is intended to provide general information only. For further details, please contact your local representative of NADIR Filtration.

Please read the following instructions carefully before handling all MOLSEP[®] Hollow fibre modules. Observe the recommendations and operating conditions very carefully. Wrong handling or operating conditions can lead to decreased performance or even to module damage. In case of questions or problems, please contact your sales representative or our technical customer service at:

NADIR Filtration GmbH
Industriepark Kalle-Albert
Rheingaustraße 190 - 196
D-65203 Wiesbaden

Phone: ++49-(0)611/962-6001
Fax: ++49-(0)611/962-9237

info@nadir-filtration.de
www.nadir-filtration.de

NOTE:

This information is based on our latest state of knowledge and is intended to provide only general notes on our products. At any time we reserve the right to make modifications due to new developments. Any existing property rights must be observed. Our products are sold under our General Conditions of Purchase and Sale. NADIR Filtration does not accept any warranties other than these stated in our General Conditions of Purchase and Sale. Explicitly, we do not give performance or lifetime warranties. Our products are ultra- and nanofiltration membrane and devices which are intended for use by especially trained personnel only. We do not accept liability for any inquiry or damages to persons, equipment or products caused directly or indirectly by the use of the products offered herein. Any warranty for product delivered in a defective state is limited to replacement of said product only.

MOLSEP[®] is a registered Trademark of DAICEN Membrane Systems Ltd., JAPAN.



2. Description of MOLSEP® Hollow Fibre Module

MOLSEP® Hollow Fibre Modules are based on the doubly asymmetric MOLSEP membrane providing high mechanical strength. This and the wide range of membrane types make MOLSEP Hollow Fibre Modules suited for all applications that require high packing density and purity Membrane of various cut offs made from polyethersulfone, polyacrylonitrile and cellulose acetate are available. Hollow fibre inner diameters range from 0.5 mm to 1.0 mm, module sizes from 0.02 to 50 m². MOLSEP® Hollow Fibre Modules have proven particularly successful in wine filtration, pure water production, for pharmaceuticals and electronics as well as surface water treatment.

Features and Applications of MOLSEP® Hollow Fibre Modules:

Membrane material	Type	Feature	Application
Polyethersulfone	FUS	High chemical resistance, double-layered	Pure water for pharmaceuticals and electronics, wine-, vinegar and juice filtration
Polyacrylonitrile	FUY	hydrophilic, double-layered	Juice filtration, pharma
Cellulosetriacetat	FUC	very hydrophilic, double-layered	(surface) water treatment

3. Module Selection

As the application suitability for each module is limited, determination of the module and membrane feasibility are best achieved by preliminary tests using a pilot test system.



4. Product Code

MOLSEP[®] Hollow Fibre Modules are available in different shapes and different membrane.

Product Code:

FS 10	FS /	FUS	0353
Module type	Arrangement Permeate outlet	Membrane polymer	Characteristics of membrane
	FS: opposite side	FUS: Polyethersulfone	(Attached you find available membrane in Table 1)
	FC: same side	FUY: Polyacrylonitrile FUC: Cellulose triacetate	

Module type

The feed runs inside the fibres at both FS10... and FE10...-Modules. The permeate is collected at the outside of the fibres (in/out filtration). Permeated liquid is discharged through one or both permeate outlets. The concentrate leaves the module at the concentrate outlet.

FS10... : fittings for feed and concentrate: 2" clamp (Sanitary)
fittings for permeate: 1" clamp (Sanitary)

FE10... : fittings for feed and concentrate: V-band coupling
2 fittings for permeate: Union Joint 16A

Please find the attached technical drawings of the modules.

FS10-FS...: see Fig.: 1 The permeate fittings are arranged at opposite sides !
FS10-FC...: see Fig.: 2 The permeate fittings are arranged at the same
FE10-FC...: see Fig.: 3 + 4 side !



Membrane polymer

Hollow fibres to be contained in these modules are grouped in FUS series and FUY series.

The **FUS** series are ultrafiltration membrane using high chemical and heat resistant **polyethersulfone membrane**. For a wide range of applications, various type of the FUS series with different molecular weight cut off's (MWCO) and fibre sizes are provided. All components constituting the module are produced from high heat resistant materials and can be heat-pasteurised.

The **FUY** series are ultrafiltration membrane using **hydrophilic polyacrylonitrile membrane**. They have a high reputation in various fields such as food processing, medical supplies production, production of pure water, and so forth. The FUY series are favourably used in fields such as fungus separation, enzyme purification, and so forth.

Please find attached tables 2 and 3, which shows the chemical resistance of the different membrane materials.

Characteristics of membrane

Due to the variety of filtration applications the membrane are available in different Molecular Weight Cut Off's (MWCO) and fibre diameters. (Please find attached table 1).

5. Condition as Supplied

The quality control of each MOLSEP[®] Hollow Fibre Module is composed of following steps.

1. Inspection of Hollow Fibre Leakage
2. Inspection of Water Permeability
3. Dimensional Inspection
4. Appearance Inspection
5. Inspection of Air-Tightness

Delivered modules have passed all these steps!

The module is filled with 20 % propylene glycol and 1 % benzoic acid to prevent the fibres from being dried out and inhibit biofouling while transport and storing.

For the module, measures against freezing in the range of about -7°C are taken.

In the fitting portion of Type FS10, the poly-cap is fixed with a vinyl tape, and in that of Type FE10, the plug plate is secured with a V-band coupling and a union joint. The module is sealed with a poly-tube, and is placed in a corrugated fibreboard case to be shipped.



6. Handling the Module

Transportation of a MOLSEP[®] module

The impact on a module by falling or collision may cause the module to crack or break. Transportation and handling of a module should be carried out with sufficient care.

Freezing of modules

Freezing of the module will cause the membrane and vessel to crack. Hence, freezing must be avoided. Handle and store the module in the environment at higher than 0 °C.

Drying of a MOLSEP[®] module

The module is sealed in its package. When the module is taken out of the package and left uncontained, the membrane can dry out. Drying of the membrane may result in irreversible damage. Sealing is necessary for longterm storage.

Organic solvents

Contact of module casing with organic solvent must be avoided. It is possible that the contact of a module casing with an organic solvent or the use of a splicing tape leads to damage of the casing. In order to remove soiling from the casing, the casing should be wiped with water or ethanol.

Sun / UV Exposure of a MOLSEP[®] module

Exposure to direct sunlight or ultraviolet rays from such sources as germicidal lamps, even indoors, may deteriorate components of the module. Modules should be stored in the dark.

Dead-end Filtration

If the concentrate outlet is plugged (dead-end mode) the filtration capacity will reduce rapidly.

Returning a MOLSEP[®] module

In the case of returning a module to NADIR Filtration, please inform the NADIR Filtration representative of the module serial number. Cleanse the module, fill it with preservative solution, seal watertight, package carefully to avoid transport damage and send it to the indicated destination.

7. Mounting the Module

While designing and installing the piping, please take into consideration that the module must be installed free of mechanical stress. Flexible tubing should be applied



(if possible) to compensate vibrations and thermal expansion of the pipes and the module.

The module should be attached for use in the following procedure:

- I. Take out the module from the corrugated fibre board case and check whether the module has been damaged during the transportation or not.
- II. Before mounting a module, system and tubing should be cleaned to make sure that residual foreign matter and oily materials from the system cannot enter the module.
- III. Drain the preservative solution used for shipping before mounting the module. If the module from which the preservative solution is drained is left as it is for a long time, the module will be contaminated and dried at the inside. This results in the reduction of the capacity of the membrane module.
- IV. Use a clamping ring to attach the module to the plant!

Attach the module in such a way that liquid will flow in the liquid-flow direction due to the arrow mark on the module label. First connect the feed clamp, then connect the concentration clamp and last the permeate outlets. Make sure that no distortion is caused in each connecting point. Then, carry out the regular clamping alternately. Over-tightening may cause the connectors to break! Thus, sufficient care is necessary!

Take care to avoid slipping of the seals while mounting the module.

- V. Please avoid excessive stress on the module caused by dislocating piping and connectors.

8. Start-Up Procedure

- I. Removal of sealing liquid

For the purpose of removing the sealing liquid remaining in the module, it is necessary to rinse the module by using pure water (demineralised water, etc.). Make sure of no leakage from the connection points of the apparatus. If leakage occurs, stop the operation and take measures such as further clamping.

It is very important that residual air is completely removed from the system by low pressure operation. Increase gradually the amount of rinsing water to that of water specified for regular operation and carry out the rinsing for at least 20 minutes. In this case, drain completely the permeated water and the concentrated water.

- II. Filtration of feed

It is very important that residual air is completely removed from the system by low pressure operation (prevention of air hammer).

Avoid increasing rapidly the pressure and the flow rate at start-up. Adjust gradually them to the specified conditions and then operate the apparatus.



9. Operating Conditions

In table 1 you will find the limits of operating conditions. In order to control the flow rate and pressure of the system, it is necessary to equip the membrane system with flow rate regulating valves, pressure regulating valves and measurement instruments (not part of supply).

The optimal flow rates differ depending on. A high flow rate limits the formation of a fouling layer on the membrane and keeps the permeate flux on a high level.

The permeate flux also depends on the transmembrane pressure. Take into account that high filtration pressures raises thickness and density of the fouling layer and may result in decline of permeate flux.

pressure drop:

$$\Delta p = p_{IN} - p_{OUT}$$

transmembrane (operating) pressure:

$$p_{TMP} = \frac{p_{IN} + p_{OUT}}{2} - p_{Perm}$$

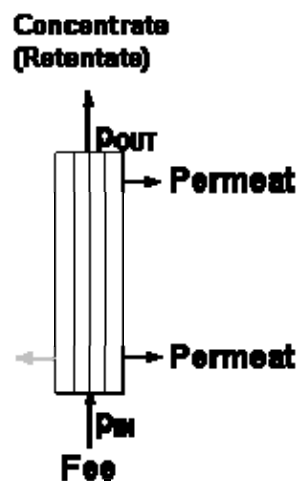

NOTE:

It is necessary to find optimal flow rate and transmembrane pressure by carrying out preliminary tests!

10. Cleaning and Regeneration

During operation of the module, the filtration capacity will reduce gradually. It is necessary to recover the performance by periodic cleaning. Some cleaning systems will be described below.

Cleaning by circulating water (See attached figure 8)

Stop the feed supply. Drain the feed tank and the whole plant. Fill pure water in the feed tank. Prior to circulation, a short term of rinsing to substitute water for the liquid remaining in the module. During rinsing drain the concentrate.

Switch the valves in this way that permeate and concentrate will return to the feed tank (cleaning modus). Then circulate the pure water with the feed pump for about 20 minutes. Drain the feed tank and the whole plant and then return to the filtration mode.



Cleaning by forward backward switching

In the apparatus shown in Fig. 6, the feed supply can be switched to flow in the forward or backward direction. This cleaning is effective in removing clogging matters at the end sides of the module. Moreover, this method combined with cleaning by backwashing is expected to have a high cleaning effect.

Cleaning by backwashing

As shown in Fig. 5 and 6 the feed pump is stopped and the valve on the permeated liquid side is closed. The permeated liquid is pushed by the backwashing pump through the permeate port at a low pressure and flow rate. The permeate runs through the pores of the membrane in opposite direction. The fouling layer on the membrane surface is removed and discharged from the system through the concentrate outlet. The optimal interval of backwashing depends on the recovery of permeate flux and the loss of backwashed permeate.

NOTE:

Only permeate is suitable for backwashing!

Cleaning by hot water pasteurisation

This method of cleaning is suitable for FUS-modules only!

NOTE:

The maximum temperature is 40 °C for use FUY type modules ! The cleaning of FUY type modules by hot water pasteurisation will destroy the module!

The FUS type modules are heat-resistant ultrafiltration modules. The pasteurisation at the inside of the system recovers the permeate flux.

For pasteurisation use a circulating membrane system (see figure 8) Heat up the circulating water **gradually** up to 80 °C. The durabilities of fibres and housing are different with temperatures. Use the module in the conditions of Table 1. Take care not to cause rapid changes in flow rate and pressure.

It is effective to maintain the piping end portions at a temperature of approx. 80 °C for 1 hour. Avoid passing raw steam directly through the module.

After cleaning decrease slowly the temperature (10 °C / min) and discharge the concentrate because of containing amount of unfiltered substances due to the cleaning effect.

Cleaning by chemicals

When the flux recovery with water is insufficient, it is recommended to carry out the following chemical cleaning.

Inorganic Soiling:

- citric acid: 1 - 2 % or



- oxalic acid: 1 - 2 %

Organic Soiling:

- NaOH : 0.05 – 0.5 %
- NaOCl : 100 – 500 ppm (effective chlorine)

Provide a chemical solution into a cleaning tank. Circulate the solution in the ordinary operation conditions so that the permeate and the concentrate are led back to the cleaning tank. Continue this circulation operation for 30 – 60 minutes. Discharge chemical solution from the system and rinse with pure water for 20 minutes.

11. Pasteurisation

The following methods of pasteurising the module are recommended:

- Hot water circulation pasteurisation. This method is described in detail in chapter 10.
- Circulation cleaning for 30 minutes by using 200 ppm sodium hypochlorite (NaOCl) aqueous solution.
- Circulation cleaning for 80 minutes by using 1% Formaldehyde aqueous solution.

12. Long-term Storage

Clean thoroughly the module and keep it in a wet state. Use either of the following preservatives in order to prevent biofouling during storage.

- Formaldehyde: 0.5 %
- Sodium bisulfite (NaHSO_3): 1 %

Close the module with the original caps. Store the module in a horizontal position. Prevent the module from direct sunlight. The storage temperature should be in the range of 5 – 30 °C.

13. Module Lifetime

The end of the module's lifetime has been reached, when the separation characteristics of a module cannot be restored by cleaning, or when permeate flux has de-graded considerably. Please contact your representative of NADIR Filtration for re-placement.



Table 1: Specification and operating conditions

Module type	FS 10-FS, FS 10-FC			FE10-FC		FS 10-FS	
Hollow fibre type	FUS 0353	FUS 0382	FUS 1581	FUS 0353	FUS 1581	FUY 03A1	
Specifications:							
Ø hollow fibre inside / outside [mm]	0,50 / 0,80	0,80 / 1,3	0,80 / 1,3	0,50 / 0,80	0,80 / 1,3	1,0 / 1,6	
effective membrane area [m ²]	8,2	5.3	5.3	8.2	5.3	4.4	
module diameter [mm]	89	89	89	89	89	89	
module length [mm]	1129	1129	1129	1126	1126	1129	
fitting size:							
feed / concentrate	2" Clamp	2" Clamp	2" Clamp	V-band	V-band	2" Clamp	
permeate	1" Clamp	1" Clamp	1" Clamp	Union Joint	Union Joint	1" Clamp	
Performance:							
M W C O [Da]	30.000	30.000	150.000	30.000	150.000	30.000	
Pure water flux at 25 °C, 1 bar [l / h Module.]	3.500	2.700	4.000	3.500	4.000	1.100	
Maximum Temperature:							
	95°C (for cleaning)					45 °C	
Operating conditions:							
	◀ FUS 0353, 0382 ▶			◀ FUS 1581 ▶			
Temperature [°C]	5 – 50	50 – 80	80 – 95	5 – 50	50 – 80	80 – 95	5 – 45
Max. transmembrane pressure [bar]	3,0	2,0	1,0	2,5	1,5	0,5	3,0
Max. feed pressure [bar]	6,0	4,0	2,0	6,0	4,0	2,0	6,0
pH-range:							
	1 - 14					2 - 12	
Cross flow (for 1 m / s): [l / h]							
	3.800					4.000	
Materials:							
hollow fibre				Polyethersulfone		Polyacrylonitrile	
module housing				Polysulfone		Polysulfone	
adhesive (potting)				Epoxy resin		Epoxy resin	
O-Ring				PTFE		PTFE	
Preservative:							
	20 % propylene glycol + 1 % benzoic acid						
Module weight:							
empty [kg]				2,5			
filled with water [kg]				8,5			



Table 2: Chemical resistance of polyethersulfone membrane (FUS-Module)

Chemicals	Concentration	Temperature	Duration	Evaluation
HCl	pH 2,0	80 °C	30 days	+
	pH 1,5	80 °C	30 days	-
H ₂ SO ₄	pH 2,0	60 °C	30 days	+
HNO ₃	pH 2,0	60 °C	30 days	+
Citric acid	1 %	60 °C	30 days	+
NaOCl	1 %	25 °C	30 days	+
	1 %	60 °C	30 days	0
HCHO	3 %	80 °C	30 days	+
	35 %	25 °C	30 days	+
	35 %	80 °C	30 days	-
Ethyl alcohol	100 %	25 °C	30 days	+
	70 %	25 °C	30 days	+
	70 %	80 °C	30 days	-
NaOH	pH 14	60 °C	30 days	+

Table 3: Chemical resistance of polyacrylonitrile membrane (FUY-Module)

Chemicals	Concentration	Temperature	Duration	Evaluation
HCl	pH 2	room temperature	6 days	+
		40 °C	1,5 days	+
Acetic acid	1 %	room temperature	6 days	+
		40 °C	1,5 days	0
NaOH	pH 12	room temperature	6 days	+
		40 °C	1,5 days	0
NaOH	pH 13	room temperature	6 days	-
		40°C	1,5 days	-

Evaluation:

- + usable: The changes in membrane capacity and membrane strength are less than 30% of the initial values.
- 0 influence: Membrane strength and capacity changed 30 - 50 %.
- not allowed: Membrane strength and capacity changed more than 50 %.



Fig. 1: MOLSEP® Hollow Fibre Module, Type: FS10-FS

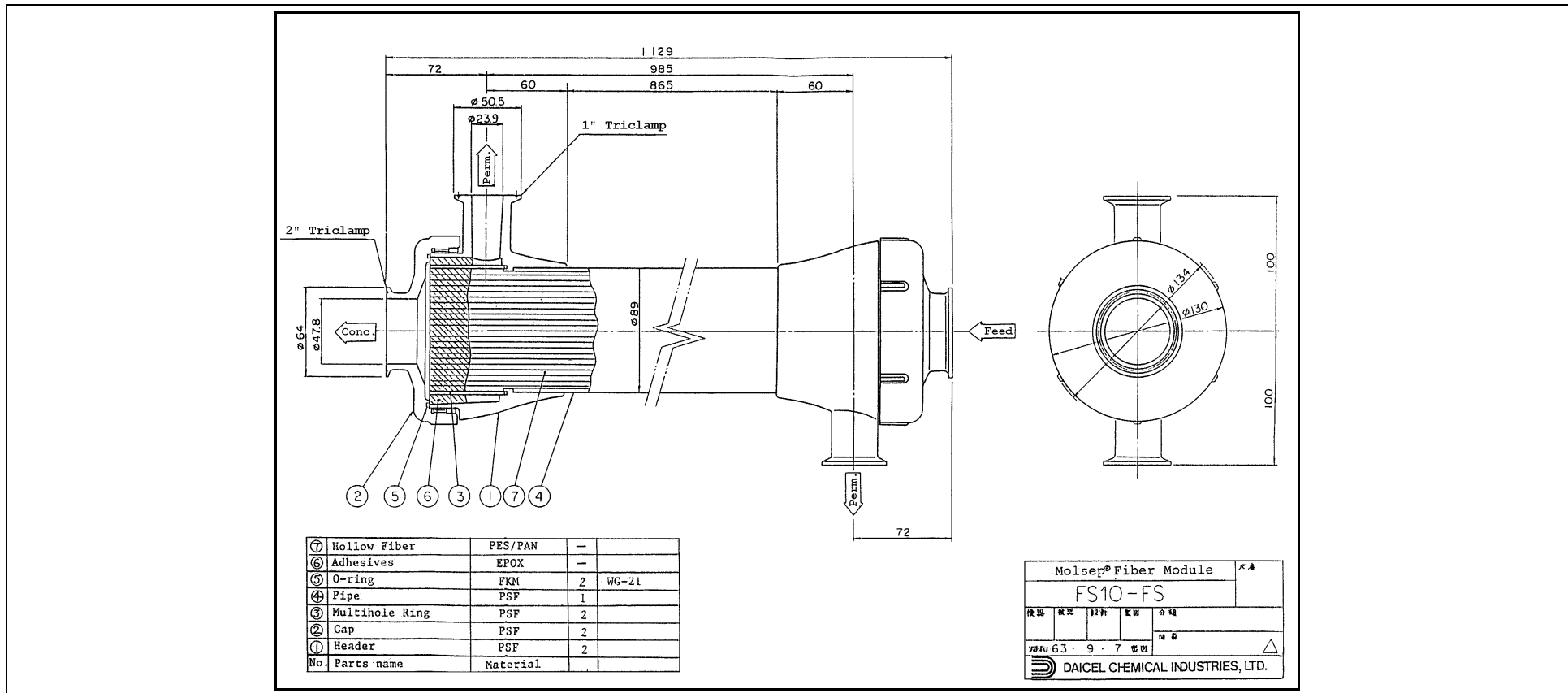



Fig. 2: MOLSEP® Hollow Fibre Module, Type: FS10-FC

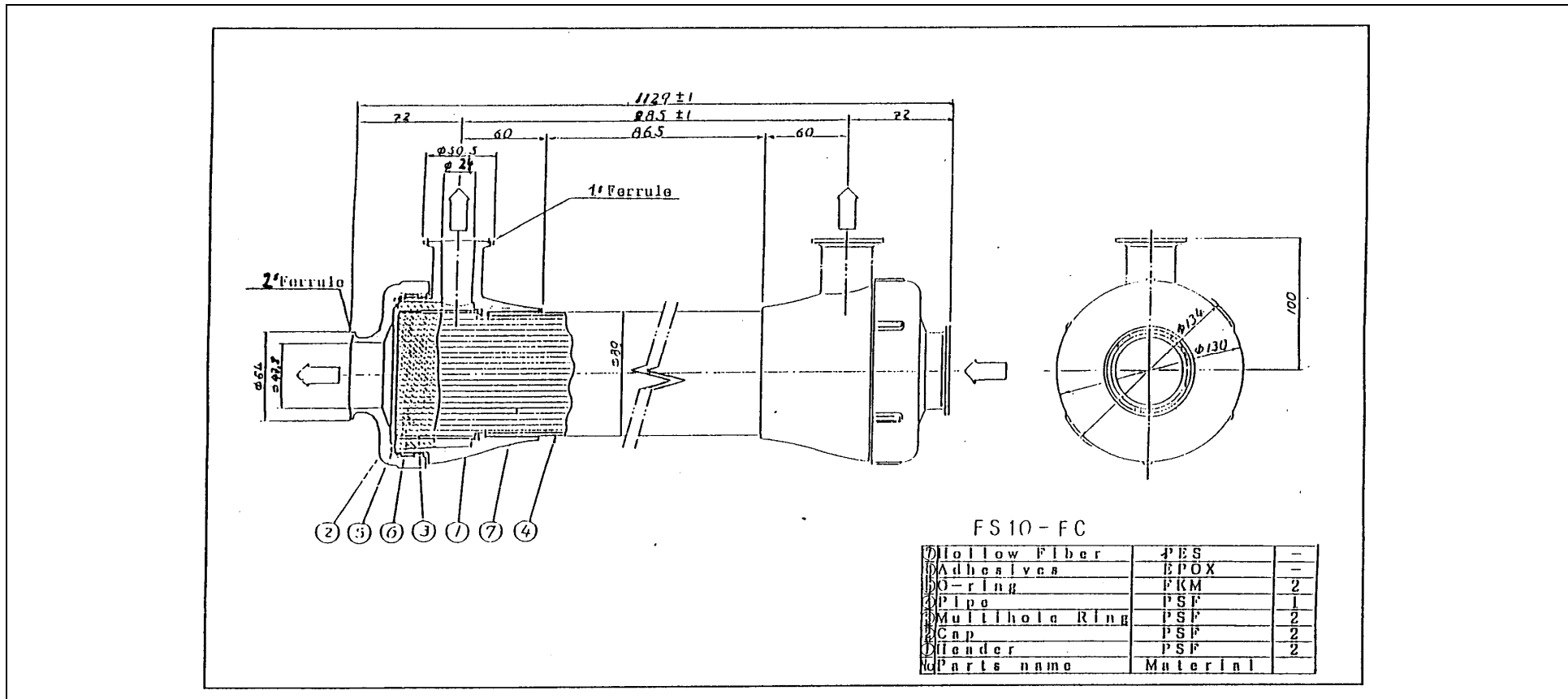



Fig. 3: MOLSEP® Hollow Fibre Module, Type: FE10-FC

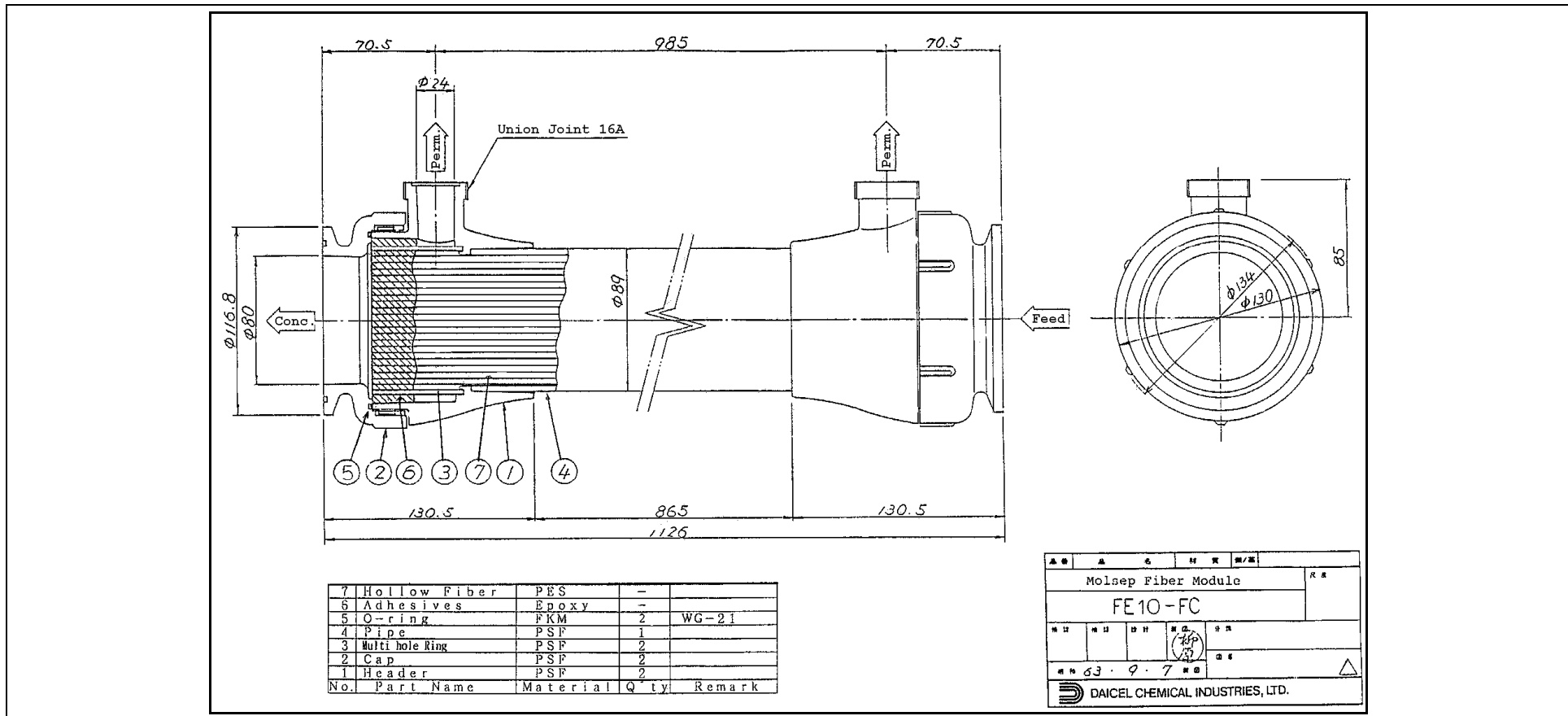



Fig. 4: MOLSEP® Hollow Fibre Module, Type: FE10-FC (with connections)

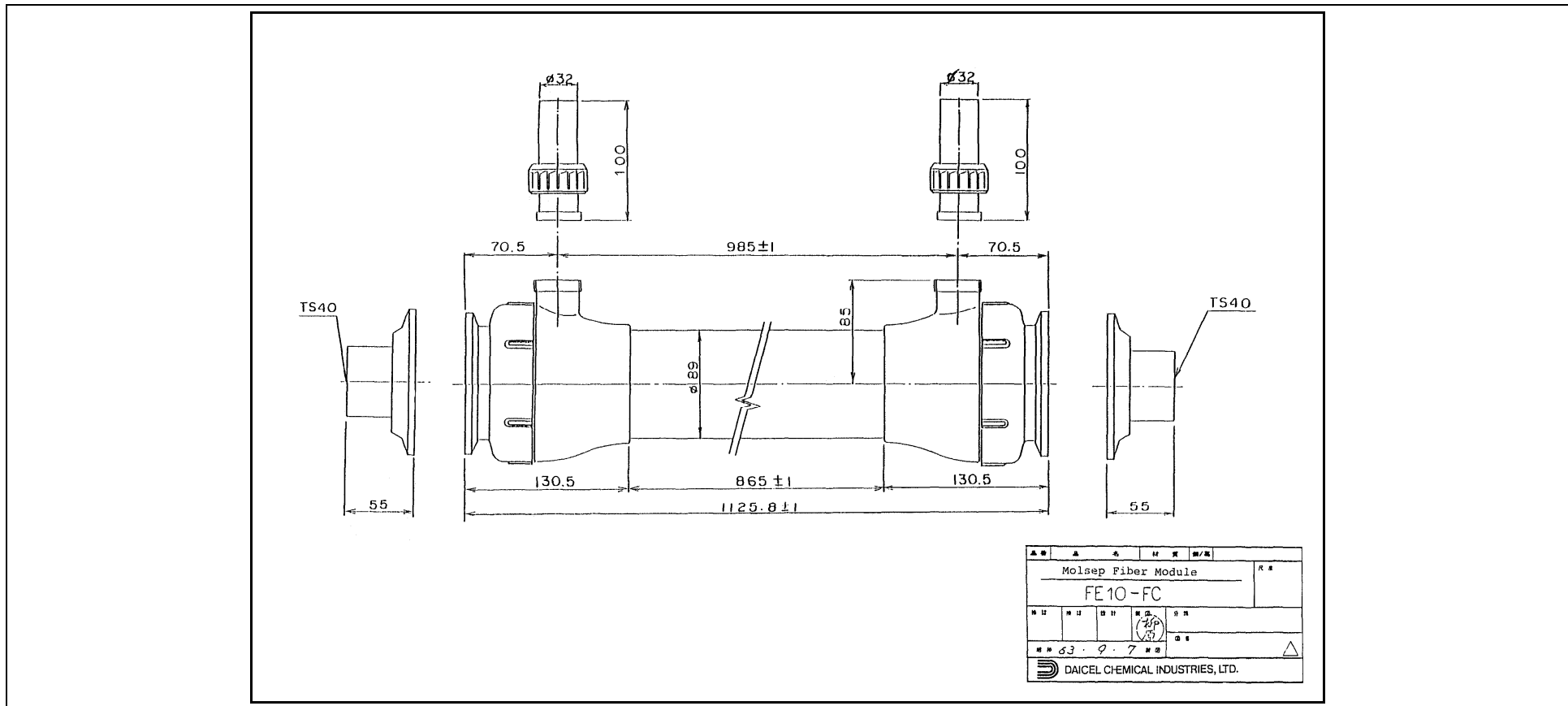



Fig. 5: Membrane with backwashing

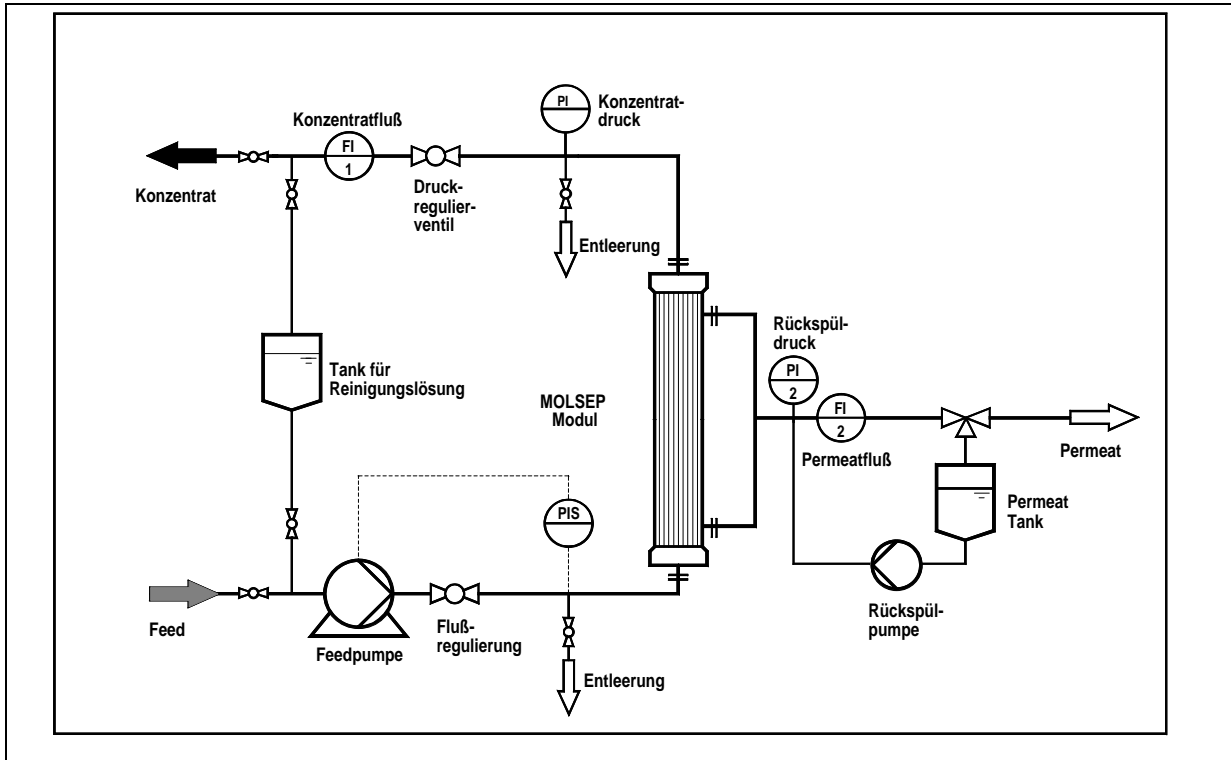

Fig. 6: Forward, backward switching membrane system with backwashing

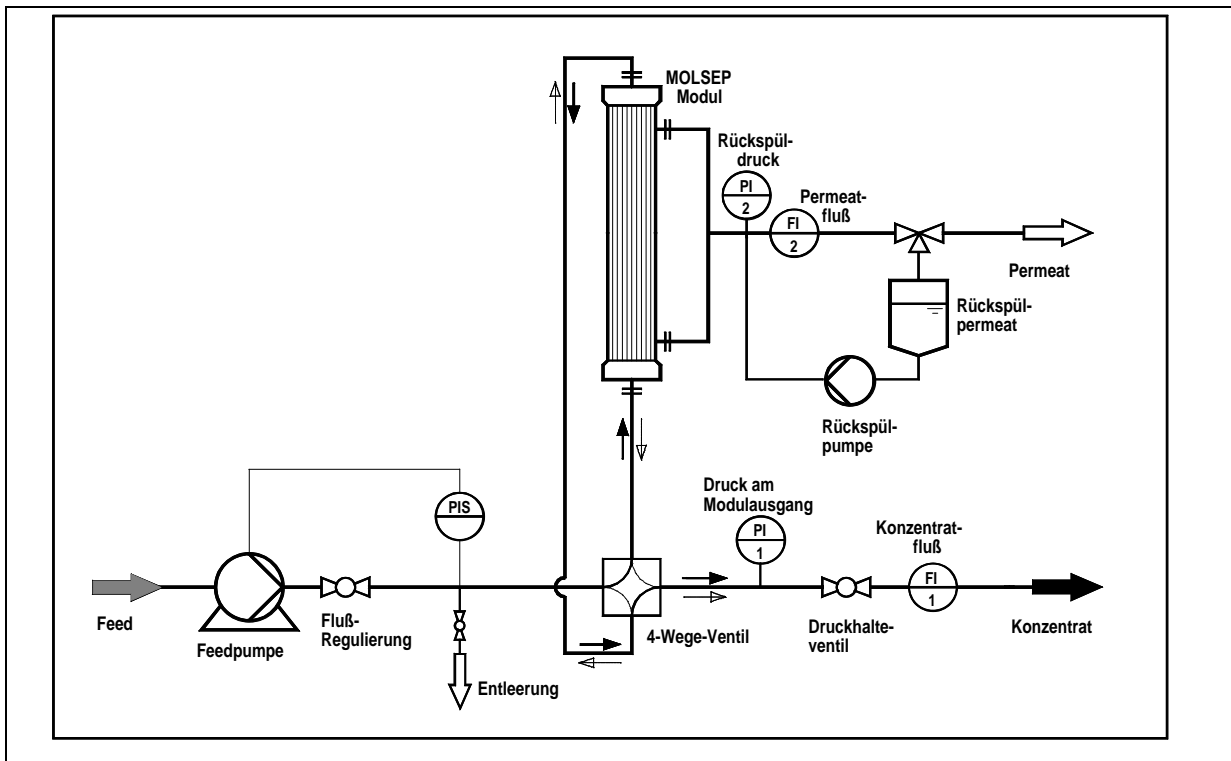



Fig. 7: Membrane system without backwashing

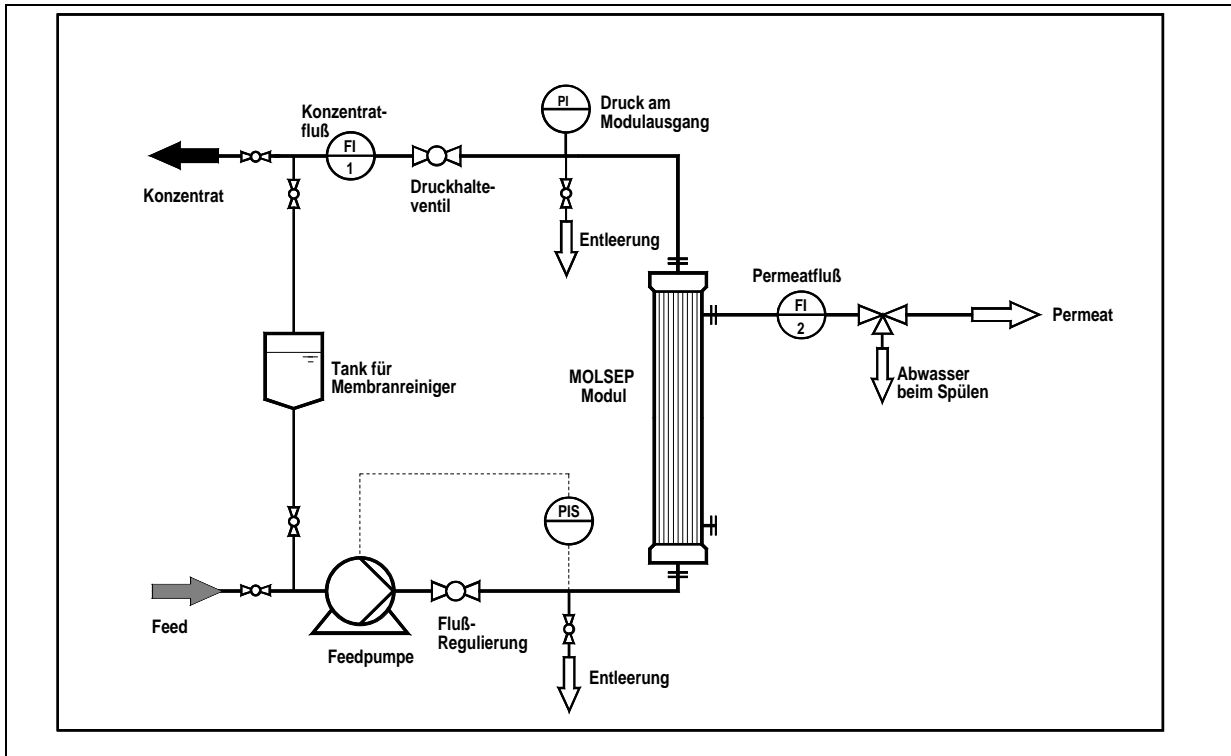

Fig. 8: Circulating membrane without backwashing

